

SUMP VACUUM CLEANERS FOR OIL AND CHIPS

RAM OIL 500

INDUSTRIAL VACUUM CLEANER FOR LUBRICATING OILS AND SHAVINGS



Guarda il video!



POTENZA
4,3 kW - 5,8 HP



APPLICAZIONE
Oils and lubricants mixed shavings

VANTAGGI

- Filters and reuses lubricating and cutting oils
- Simultaneous liquid suction and discharge capability
- Simplified liquid collection and swarf management
- Sturdy painted steel construction

HIGHLIGHTS

SUCTION UNIT

The suction unit is a side channel blower with direct coupling between motor and impeller. The turbine is equipped with a safety valve to ensure continuous, maintenance-free work. A metal silencer is included as standard in the turbine to ensure a low noise level.

FILTER UNIT

The collected liquid passes through a washable PPL filter with an efficiency of 150µ and a grid basket, which trap chips and simplify their disposal. In this way, even the smallest solid particles can be separated, making the filtered liquid suitable for reuse.

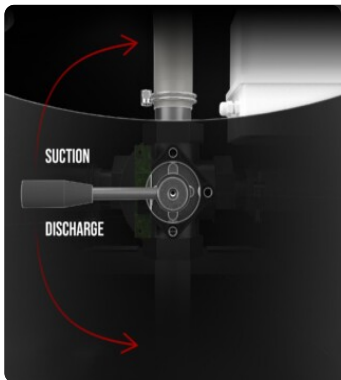
LIQUID DISCHARGE SYSTEM

A convenient lever, located at the rear of the vacuum cleaner, allows rapid switching between suction and container emptying. The reverse flow system uses the exhaust air from the turbine ensuring the efficiency and speed of the operation.

ACCESSORY KIT INCLUDED

A complete and functional accessory kit is included in the standard equipment of the vacuum cleaner

TECHNICAL DATA
MOTORE

Tipologie	Side channel blower
Potenza	4,3 kW - 5,8 HP
Frequenza	50/60 Hz
Voltaggio	400 V
Vuoto in continuo	360 mBar
Massima portata d'aria	320 m ³ /h
Classe di isolamento	55 F IP
Livello di rumorosità	72 dB(A)

MACCHINA

Bocca aspirante	50 Ø mm
Sistema di raccolta	Steel container
Capacità solido	40 lt
Capacità liquido	500 lt
Sistema di scarico liquidi	Reverse flow
Tempo di aspirazione	500/120 lt/sec
Tempo di scarico	500/120 lt/sec
Dimensioni	600 x 1510 mm
Altezza	1780 mm
Peso	220 Kg
Kit accessori incluso	P12352
Separazione solido	Basket grid
Separazione liquidi	PPL bag 150µm
Valvola di sicurezza	Pressure relief valve

FILTRAZIONE

Tipologia filtro primario	Bag
Media	Polypropylene 150µm

DOTAZIONI



P12352 OIL & SWARF KIT

Basic kit containing specific accessories for 50 mm diameter oil and swarf vacuuming application



OIL-PROOF CARTRIDGE

Oil-proof cartridge for motor protection



HOSE WITH DISCHARGE VALVE



PLUG

4-pole industrial plug



HOSE HOOK



POWER SUPPLY CABLE



WHEEL WITH BRAKE

Non-marking wheel with integrated brake



WHEELS

Non-marking pivoting wheels



STEEL CONSTRUCTION

Rugged industrial coated steel construction



PRV

Pressure relief valve installed

OPTIONS

STRUCTURE AND OPTIONS

60[✓]HZ

60HZ
Available in 60Hz version



BIS
Inspection door for internal maintenance



LIQUID DISCHARGE PUMP
Allows simultaneous suction and discharge of liquid

ACCESSORIES



P12355
OIL & SWARF KIT PRO Ø 50MM
Kit containing specific accessories for 50 mm diameter oil and swarf vacuuming application